

Your Local Okada Dealer

TROMMEL SCREENING BUCKETS
COMPACTORS | PULVERIZERS
GRAPPLES | CUTTERS | SCRAP SHEARS

COUNT ON OKADA.

WWW.OKADAAMERICA.COM



Since 1995, Okada America, Inc. has been offering a wide variety of attachments through its parent company, Okada Aiyon located in Osaka, Japan.

Okada Aiyon was established in 1938 manufacturing a single line of breakers that has evolved into a global company producing a full line of demolition attachments.

The Okada family remains active in daily operations, still demands precision engineering with stringent quality control that ensures long product life and consistent quality output. These proven manufacturing guidelines are what drives Okada to remain the global industry leader for hydraulic attachments.



OREGON

12950 SE HWY 212 BLDG D
CLACKAMAS, OR 97015
503.557.7033 | F 503.557.7779

OHIO

904 MEDINA RD.
MEDINA, OH 44256
330.239.2666 | F 330.239.3670

TEXAS

3575 WINDMILL RD. BLDG.#2
JOSHUA, TX 76058

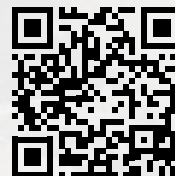

**TOP SERIES
HYDRAULIC BREAKERS**





COUNT ON OKADA.

TOP SERIES HYDRAULIC BREAKERS

Okada's TOP Series line of hydraulic breakers provides a wide range of models to fit the most demanding of applications. Our TOP breakers are the result of decades-long field experience and Okada's long-standing industry leadership.

Sixteen models to offer a wide range of carrier compatibility from 1,600 to 220,000 pounds, TOP Series offers a breaker for any job.

Okada's technology ensures efficiency, increased performance and less down-time which provide higher profitability for your business.

OKADA TECHNOLOGY

Advanced Okada technology eliminates the need for an accumulator without affecting the hydraulic apparatus on the carrier, reducing both maintenance costs and downtime.

Precision machining processes and strict Okada quality control are used to produce all main breaker components. There is no need for complete assembly replacements and the use of high precision parts equate to economical, labor-saving rebuilds of your Okada breaker.

ACCUMULATOR

Used to reduce pressure spikes in supply and return lines to protect the carrier hydraulic system. The high pressure accumulator is field repairable without removing the breaker from its mounting.

SEALS

Cup seals are utilized to secure the flow in the oil and gas chambers.

NITROGEN GAS

Cushions the piston on the upstroke, eliminating the need for shock absorbers, and increases the piston down stroke force.

AUTO-LUBE

A central grease port with internal grease passage allows to easily adapt the hammer to most auto-lube systems.

CHISEL SET PIN

Heavy-duty chisel set pins in many Okada TOP models offers extended service life.

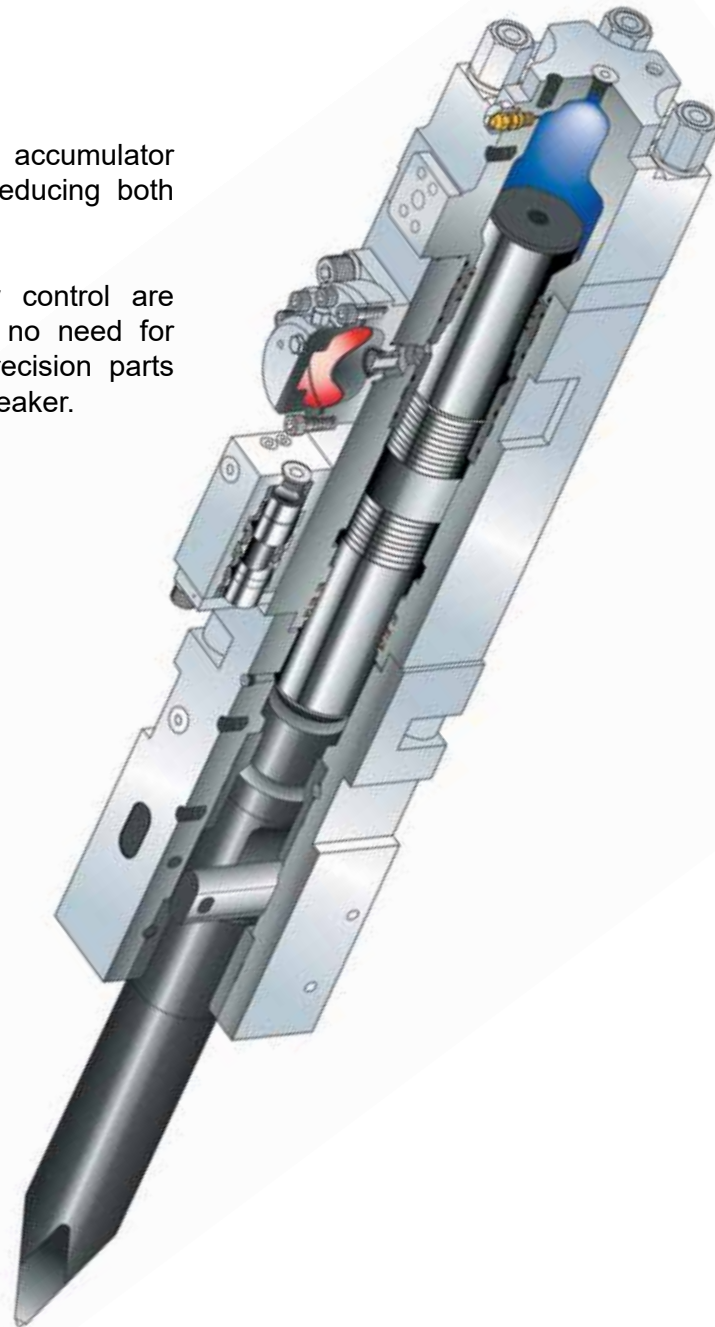

COUNT ON OKADA.



WORKING TOOLS

Selected special high quality steel and the most advanced heat treatment available anywhere ensure outstanding wear and shock resistance.



SERVICE TOOLS

Hydraulic breaker service tools provide end-users with the best quality tools to keep your breaker attachments running at their peak performance.



AUTO-LUBE SYSTEM





COUNT ON OKADA.

TOP SERIES GENERAL CARRIER RANGES & APPLICATIONS

Models	CARRIER RANGE IN METRIC TONS																				
	1	5	10	15	20	25	30	35	40	45	50	55	60	65	70	75	80	85	90	95	100
21LT (.7 - 2.3)	■	■	■																		
21H (1 - 2.3)	■	■	■																		
31 (1.5 - 4)	■	■	■	■																	
35B (2 - 4)	■	■	■	■																	
45B (4.5 - 8)		■	■	■	■	■															
55B (4.5 - 8)		■	■	■	■	■	■														
60B (5 - 9)		■	■	■	■	■	■	■													
90 (7 - 12)		■	■	■	■	■	■	■	■												
100A (10 - 18)			■	■	■	■	■	■	■	■											
150 (13 - 19)			■	■	■	■	■	■	■	■	■										
205J (18 - 27)				■	■	■	■	■	■	■	■	■									
270 (20 - 30)					■	■	■	■	■	■	■	■	■								
300 (28 - 52)						■	■	■	■	■	■	■	■	■	■	■	■	■	■	■	■
400 (40 - 60)							■	■	■	■	■	■	■	■	■	■	■	■	■	■	■
800 (50 - 80)								■	■	■	■	■	■	■	■	■	■	■	■	■	■
1000 (75 - 100)									■	■	■	■	■	■	■	■	■	■	■	■	■

The above chart is for general reference only. For specific application and system requirements, contact Okada or your Okada dealer.

AGGREGATE PRODUCERS • BRIDGE CONTRACTORS • CONCRETE & PAVING CONTRACTORS • DEMOLITION CONTRACTORS • EXCAVATION CONTRACTORS • SITE CONTRACTORS • GENERAL & SPECIALTY CONTRACTORS • INDUSTRIAL CONTRACTORS • MUNICIPALITY & UTILITY CONTRACTORS • PLUMBERS & PIPELINE CONTRACTORS • UTILITIES (GAS, WATER, ELECTRIC) • FOUNDRIES & SMELTERS

COUNT ON OKADA.



TOP SERIES BRACKET CONFIGURATIONS

SKID-STEER LOADER BRACKETS

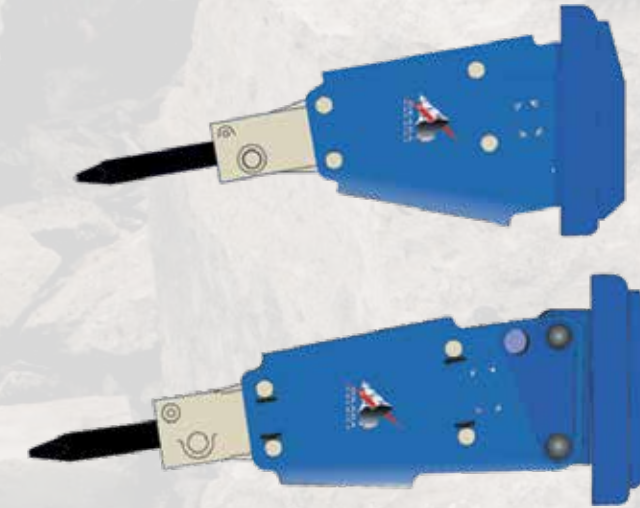

Custom-engineered single and two-position brackets will give you excellent results on many popular carriers. We are able to match most manufacturers quick coupler requirements.

BOX BRACKET



Box brackets are specifically designed to reduce the amount of sound emitted from the equipment.

VERTICAL BRACKET

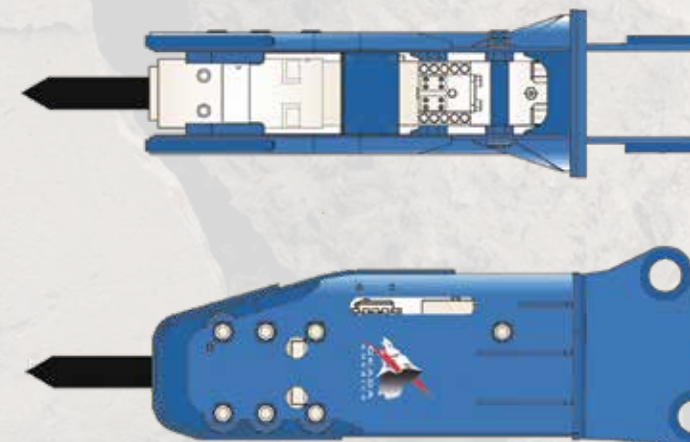

Vertical brackets are the most commonly used mounting method. The upper mount bracket can be used together with quick-coupler systems on a variety of carriers.





SPECIFICATIONS



	MODEL	TOP21LT	TOP21H	TOP35B	TOP45B	TOP55B	TOP60B	TOP90	TOP100A	TOP150	TOP205J	TOP270B	TOP300	TOP400	TOP800	TOP1000
INFORMATION																
Carrier Class	lbs (1000)	1.6 - 5	2.2 - 5	4.4 - 8.8	10 - 18	10 - 18	12 - 20	15 - 26	22 - 42	28 - 42	40 - 60	44 - 66	62 - 114	88 - 132	110 - 176	165 - 220
	m ton	.7 - 2.3	1 - 2.3	2 - 4	4.5 - 8	4.5 - 8	5 - 9	7 - 12	10 - 18	13 - 19	18 - 27	20 - 30	28 - 52	40 - 60	50 - 80	75 - 100
Impact Energy Class	ft lb	150	225	550	850	1000	1250	2000	2500	3000	4000	5500	7500	12000	15000	17000
	Joules	203	305	746	1153	1356	1695	2712	3390	4068	5424	7458	10170	16272	20340	23052
Operating Weight	lb	350	321	565	780	1060	1190	1450	2440	3000	4120	5380	6650	9350	12350	15000
	kg	159	146	256	354	481	540	658	1107	1361	1868	2440	3016	4240	5601	6800
Unit Working Length	inch	48	48	61	63	72	81	84	81	94	103	123	126	145	160	177
	cm	122	122	155	160	183	206	213	206	239	262	312	320	368	406	450
Tool Diameter	inch	1.77	1.77	2.4	2.7	2.9	3.3	3.9	4.3	4.8	5.3	5.5	6.1	6.7	7.4	8.3
	mm	45	45	61	69	74	84	99	109	122	135	140	155	170	188	210
Tool Working Length	inch	11.9	11.9	14.6	16.1	19.4	21.2	21.9	23.4	24	27.5	28.7	32.6	36.8	40.5	36
	mm	302	302	371	409	493	538	556	594	610	699	730	828	935	1029	915
Frequency	L Model bpm	550 - 1000	550 - 1000	380 - 1000	800 - 1100	400 - 800	730 - 970	550 - 850	600 - 750	370 - 430	360 - 440	400 - 500	320 - 400	320 - 400	260 - 360	200 - 280
	S Model bpm	n/a	n/a	n/a	n/a	n/a	n/a	n/a	n/a	n/a	500 - 560	600 - 700	n/a	n/a	n/a	n/a
ENERGY																
Mechanical Energy	hp	3.6 - 11	4.5 - 11	14 - 28	17 - 35	22 - 39	20 - 37	30 - 56	40 - 63	42 - 63	60 - 95	60 - 105	88 - 130	103 - 167	108 - 182	156 - 219
	kW	2.7 - 8	3.3 - 8	11 - 21	13 - 26	17 - 29	15 - 27	23 - 42	30 - 47	31 - 47	45 - 71	45 - 78	66 - 97	77 - 125	80 - 135	116 - 163
Mechanical Energy Average	hp	7.3	7.8	21	26	30.5	28.5	43	51.5	52.5	78	82.5	109	135	145	188
	kW	5.4	6	16	19	23	21	32	48	39	58	62	81	101	108	140
HYDRAULICS																
Oil Flow Range	gpm	4 - 9	5 - 9	13-17	17 - 22	15 - 23	17 - 23	22 - 31	29 - 35	30 - 35	43 - 68	47 - 63	63 - 72	74 - 95	79 - 101	92 - 110
	lpm	15 - 34	19 - 34	49 - 64	64 - 83	56 - 87	64 - 87	83 - 117	110 - 132	114 - 132	163 - 260	178 - 238	238 - 273	280 - 359	299 - 382	350 - 420
Operating Pressure	psi	1300 - 1740	1300 - 1740	1600 - 2400	1450 - 2320	2030 - 2465	1740 - 2320	2030 - 2620	2030 - 2620	2030 - 2620	2030 - 2620	2030 - 2465	2030 - 2620	2030 - 2 620	1990 - 2620	2470 - 2900
	bar	90 - 120	90 - 120	110 - 165	100 - 160	140 - 170	120 - 160	140 - 180	140 - 180	140 - 180	140 - 180	140 - 170	140 - 180	140 - 180	137 - 180	1470 - 200

- 1) The TOP Series Breakers has an open style bracket design as standard except for TOP1000. Box Housing option is also available.
- 2) The TOP205J and TOP270B models have a two-speed feature. The L- mode frequency is the normal mode.
- 3) Oil flow at no load.
- 4) Specifications are subject to change without prior notice.